

SMALLER, FASTER, LIGHTER
**COMPACT MEASURES
HUGE POWER**

TO BE MORE COMPACT,
TO BE MORE POWERFUL

2~4s 3.9KGS

Super quick, complete by one trigger

PZ-Series

18v Battery Powered Tools

Crimping, Cutting, Punch
Down

Electrical cables and electrical cabinets

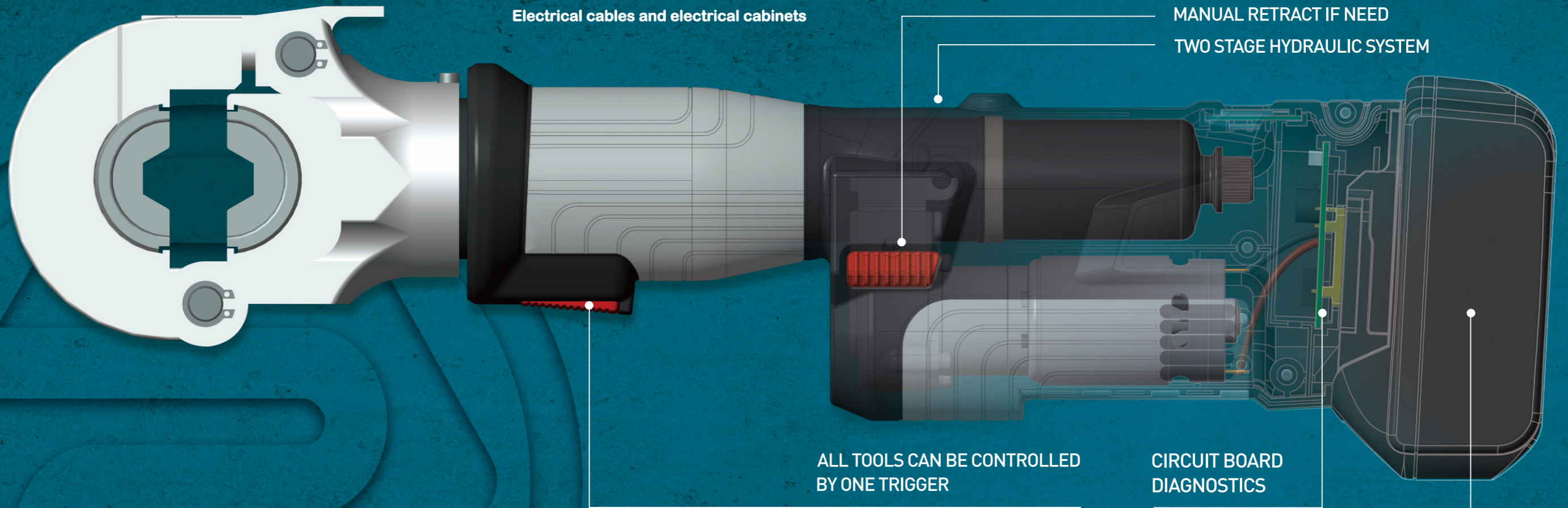

THE RIGHT TOOL FOR YOUR NEEDS

■ **CIRCUIT BOARD DIAGNOSTICS**

Alert you when the battery is low or the tool is too hot or cold

■ **OLED DISPLAY**

- Easy reading on
- Battery Percentage
- Crimping Times
- Fault Code
- Maintenance Note



- **180° SWIVELLING BARREL**
Easy access to connections
- **TWO STAGE HYDRAULIC SYSTEM**
Hydraulic Ram Output provides more force for reliable connection
- **ERGONOMIC DESIGN**
With light weight and inline grip, easily work overhead and in tight spaces.
- **SERVICE INTERVAL: 20000 Cycles**

HIGH PERFORMANCE
18V Li-ion Battery

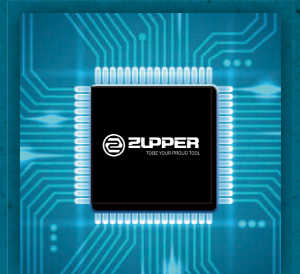

CIRCUIT BOARD DIAGNOSTICS
Alert you when the battery is low or the
tool is too hot or cold

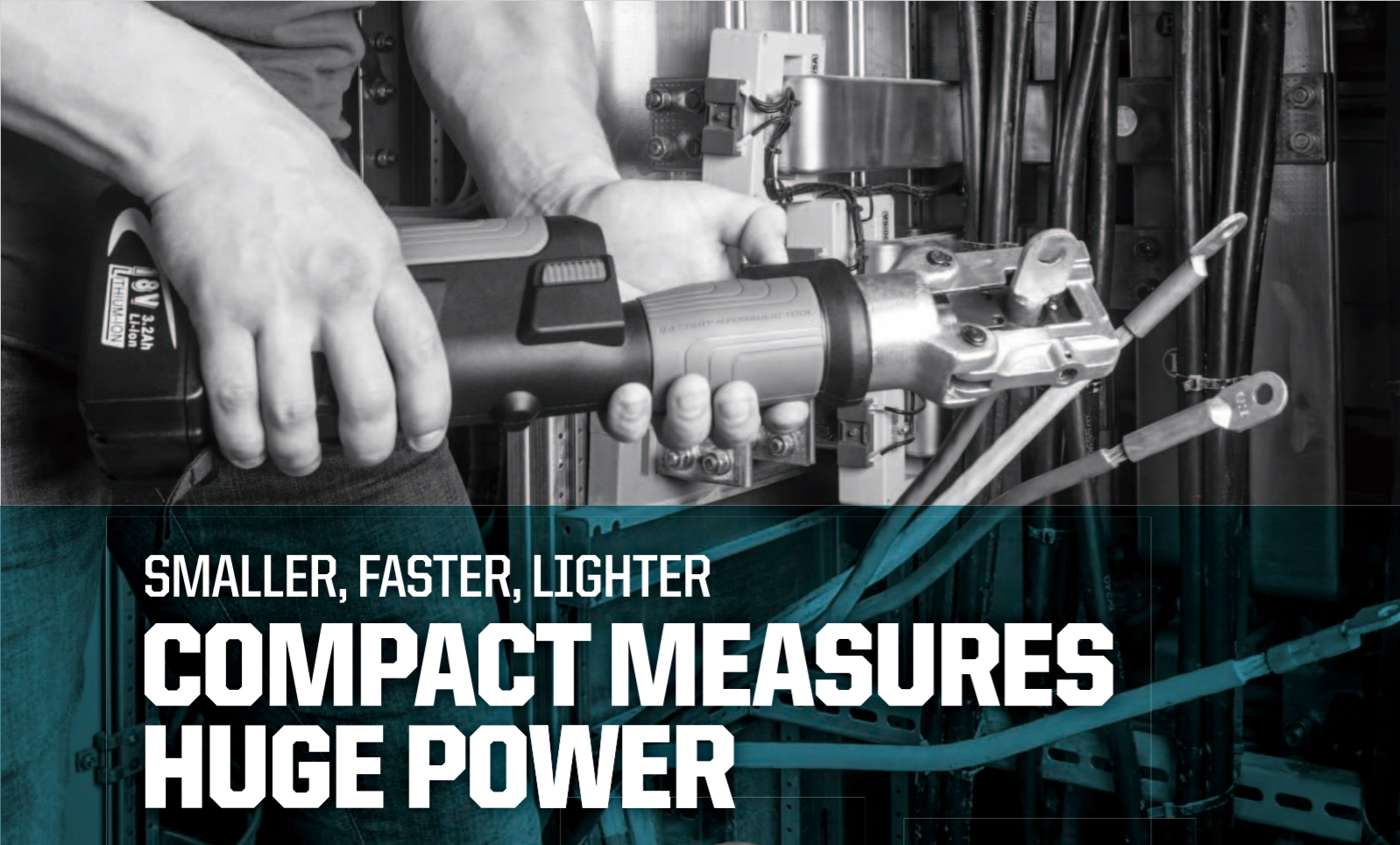

SMALLER, FASTER, LIGHTER
COMPACT MEASURES
HUGE POWER

PZ-240
PZ-300
BATTERY POWERED
CRIMPING TOOL

2.5~4s
PER CYCLE TIME

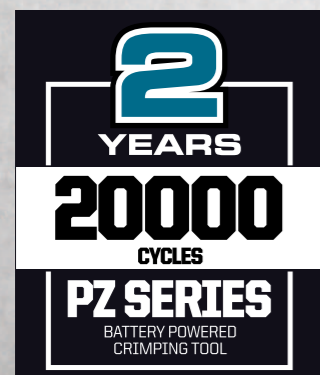

PZ-240 PZ-300

BATTERY POWERED CRIMPING TOOL

The ZUPPER PZ Series with the small size and a low weight can generate high power and performance, it is the newest addition to the mini crimp tool with in-line grip, 2-4 Seconds CRIMP cycle time.

THE RIGHT TOOL FOR YOUR NEEDS

CIRCUIT BOARD DIAGNOSTICS

Alert you when the battery is low or the tool is too hot or cold

180° SWIVELLING BARREL

Easy access to connections

TWO STAGE HYDRAULIC SYSTEM

Hydraulic Ram Output provides more force for reliable connection

ERGONOMIC DESIGN

With light weight and in-line grip, easily work overhead and in tight spaces.

OLED DISPLAY

- Easy reading on
- Battery Percentage
- Crimping Times
- Fault Code
- Maintenance Note



Technical data	PZ-240	PZ-300
Rated pressure:	50KN	60KN
Stroke:	14mm	17mm
Crimping range:	Cu 240mm ² /Al 185mm ²	Cu 300mm ² /Al 240mm ²
Time/work:	2.5-4s(depend on the dia of cable)	2.5-4s(depend on the dia of cable)
Voltage/capacity:	18V/2.5Ah	18V/2.5Ah
Charging time:	Approx.50 mins	Approx.50 mins
Charging voltage:	AC 100V-240V ;50-60Hz	AC 100V-240V ;50-60Hz
Package:	Plastic box	Plastic box
Ambient temperature:	-10-40°C	-10-40°C
Size of tool:	432x124x75mm	428x134x75mm
ACCESSORIES		
Crimping dies:	16,25,35,50,70,95,120,150,185,240 mm ²	16,25,35,50,70,95,120,150,185,240,300 mm ²
Battery:	2pcs	2pcs
Charger:	1pc	1pc
Sealing ring of cylinder:	1set	1set
Sealing ring of safety valve	1set	1set



SMALLER, FASTER, LIGHTER
TWO FUNCTIONS IN ONE TOOL
HUGE POWER

PZ-300C
BATTERY POWERED CRIMPING & CUTTING TOOL

Cutting range: $\Phi 30\text{mm}$ Cu/Al cable
Crimping range: Cu 300mm² /Al 240mm²



ONLY
2KG
2.5~4s
PER CYCLE TIME



PZ-300C

BATTERY POWERED CRIMPING & CUTTING TOOL

For operations requiring varied application, the ZUPPER offers a multi-functional tool, crimping and cutting in one single tool. The ZUPPER PZ-300C with the small size and a low weight can generate high power and performance, it is the newest addition to the mini crimp & cut tool with in-line grip, 2kgs Only, 2.5-5 Seconds work cycle time.

THE RIGHT TOOL FOR YOUR NEEDS

CIRCUIT BOARD DIAGNOSTICS

Alert you when the battery is low or the tool is too hot or cold

OLED DISPLAY

- Easy reading on
- Battery Percentage
- Working Times
- Fault Code
- Maintenance Note

180° SWIVELLING BARREL

Easy access to connections

TWO STAGE HYDRAULIC SYSTEM WITH 19KN

Hydraulic Ram Output provides more force for reliable connection

ERGONOMIC DESIGN

With light weight and in-line grip, easily work overhead and in tight spaces.



Crimping with 19KN from 16-300mm² for thin-wall terminals



Effortless cutting for Cu 300mm² /Al 240mm² cable

Technical data	PZ-300C
Rated pressure:	19KN
Stroke:	30mm
Cutting range:	$\phi 30\text{mm}$ Cu/Al cable
Crimping range:	Cu 300mm ² /Al 240mm ²
Voltage/capacity:	18V/2.5Ah
Charging time:	Approx.50 mins
Charging voltage:	AC 100V-240V ;50-60Hz
Package:	Plastic box
Weight:	2kgs(with battery) 3.4kgs(with battery and head)
Size of tool:	363x119x75mm
ACCESSORIES	
Crimping dies:	16,25,35,50,70,95,120,150,185, 240,300 mm ²
Crimping head:	1pc
Cutting head:	1pc
Battery:	2pcs
Charger:	1pc
Sealing ring of cylinder:	1set
Sealing ring of safety valve	1set



BATTERY POWERED CRIMPING TOOL

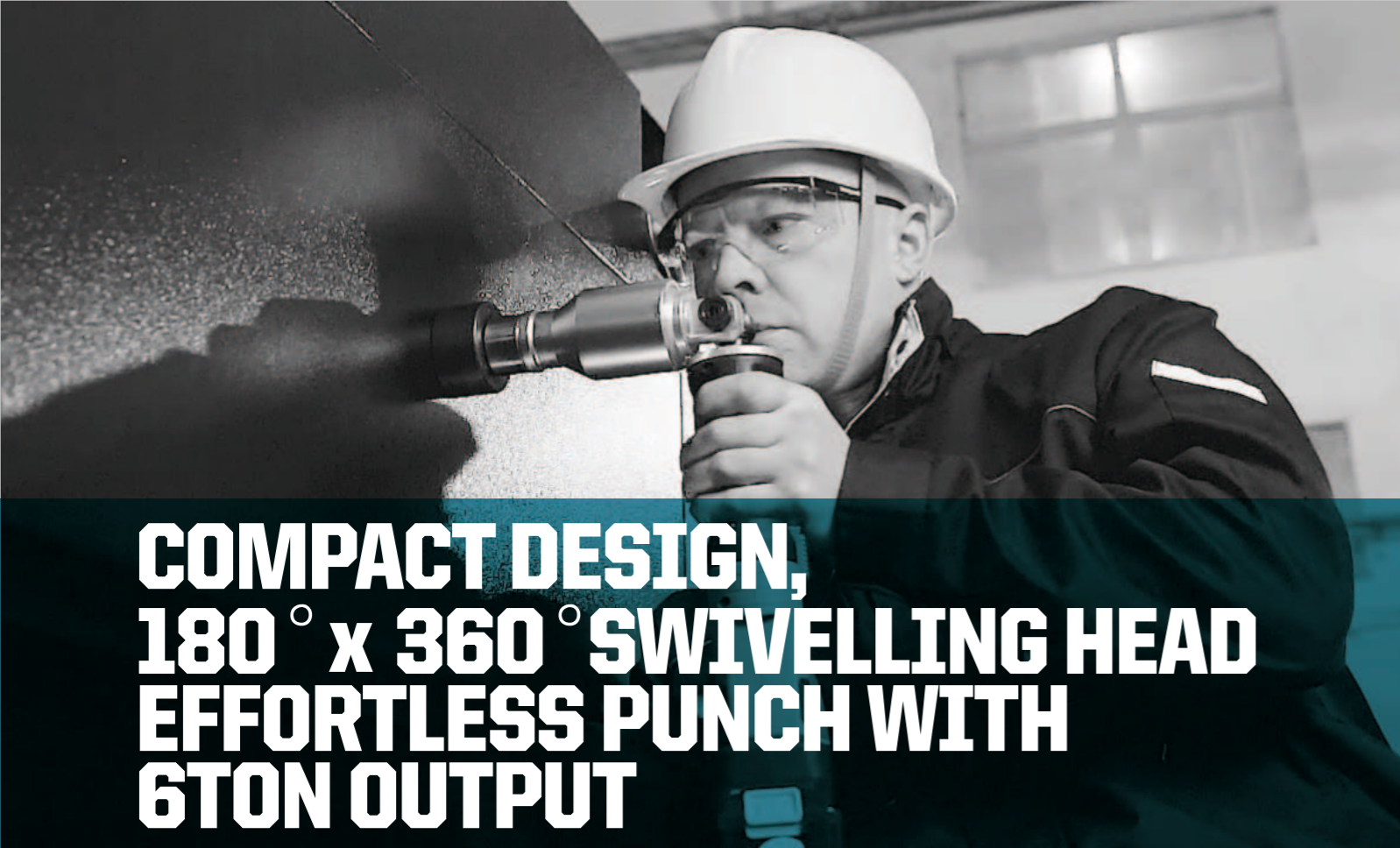

**COMPACT DESIGN,
180° x 360° SWIVELLING HEAD
EFFORTLESS PUNCH WITH
6TON OUTPUT**



2
YEARS
20000
CYCLES
PZ SERIES
BATTERY POWERED
PUNCHING TOOL

PZ-6AL
BATTERY POWERED PUNCH DRIVER

3~8s
EASY PUNCHING,
EFFICIENT AND LABOR-SAVING

PZ-6AL BATTERY POWERED PUNCH DRIVER

The ZUPPER PZ Series with the small size and a low weight can generate high power and performance, it is the newest addition to the mini punch driver with in-line grip. The working head rotatable through 360°, no matter whether for straight punchings in steel and stainless steel or confined areas with swiveling head. The tool comes standard with two 18V, 2.5Ah Li-ion batteries and one charger, motor drives, micro-computer control system, OLED display and double valve hydraulic system.

Aluminum alloy body with light weight
180°x360° swivelling head
Ergonomic design with high quality aviation aluminum

- 1.the core parts are used in general and standardized manufacturing, the quality is more guaranteed
- 2.automatic retraction when operation is complete, manual retract if required
- 3.OLED display show the battery quantity, punch times and maintenance information
- 4.powerful 18V high performance battery, high capacity, short charging time
- 5.ergonomic design, balanced centre of gravity for easy handling and effortless operation



Technical data	PZ-6AL
Rated pressure:	60KN
Stroke:	25mm
Cycles/charge:	250cycles(Max.mild steel 3mm, Φ49.6mm)
Piston rod thread:	3/4-19 UN
Max. Round Punch Size :	61.5mm Dia. in 3.5mm mild steel 161.9mm Dia. in 2mm mild steel 61.5mm Dia. in 2mm stainless steel
Voltage/capacity:	18V/2.5Ah
Charging time:	50 mins
Charging voltage:	AC 100V-240V ;50-60Hz
Package:	Plastic box
Weight:	2.6kgs
Size of tool:	452x120x75mm

DESCRIPTION	HOLE SIZE (TYPE D)		
	Φ (INCH)	Φ mm	
1/2" Conduit Size Punch&Die	7/8"	0,885	22.50
3/4" Conduit Size Punch&Die		1,115	28.30
1" Conduit Size Punch&Die		1,362	34.60
1-1/4" Conduit Size Punch&Die		1,701	43.20
1-1/2" Conduit Size Punch&Die	1-15/16"	1,951	49.60
2" Conduit Size Punch&Die	2-3/8"	2,146	61.50
7/16"x3/4" Draw Stud			1pc
3/4"x3/4" Draw Stud			1pc
Spacer			1pc
Battery:			2 pcs
Charger:			1pc
Sealing ring of cylinder:			1set
Sealing ring of safety valve:			1set



PZ-Series

18V Battery Powered Press Tools

SMALLER, FASTER, LIGHTER
**COMPACT MEASURES
HUGE POWER**

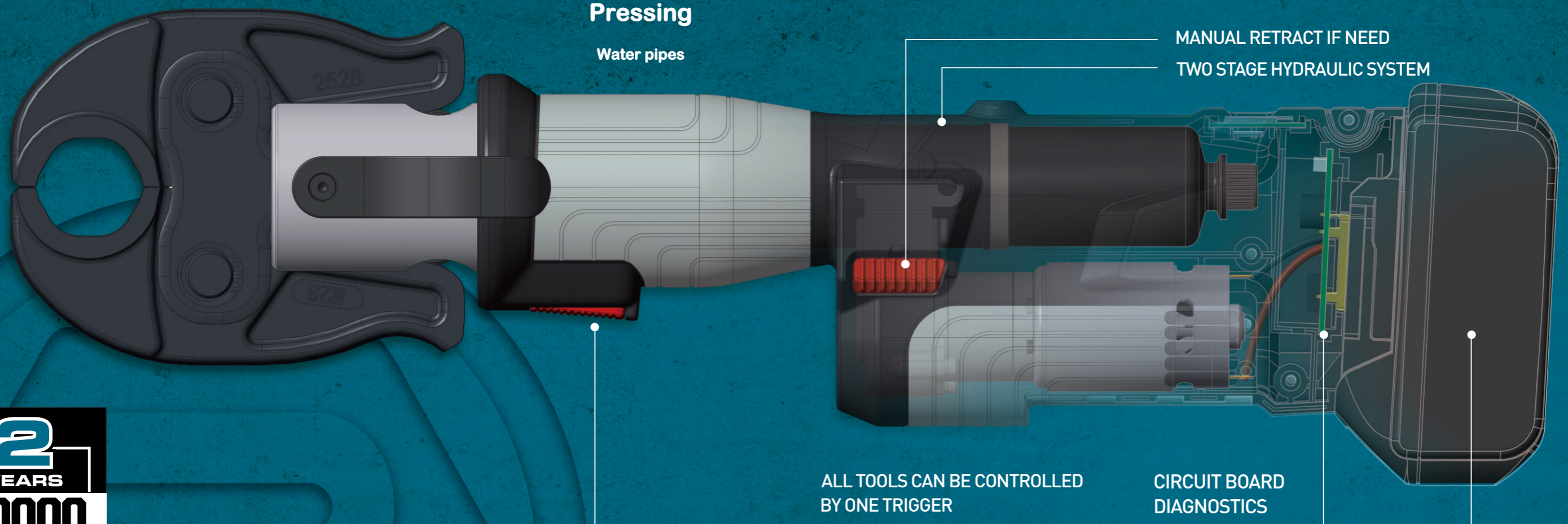

2
YEARS
30000
CYCLES
PZ SERIES
BATTERY POWERED
PRESS TOOL

THE RIGHT TOOL FOR YOUR NEEDS

■ CIRCUIT BOARD DIAGNOSTICS

Alert you when the battery is low or the tool is too hot or cold

■ OLED DISPLAY

- Easy reading on
- Battery Percentage
- Pressing Times
- Fault Code
- Maintenance Note

■ 180° SWIVELLING BARREL

Easy access to connections

■ TWO STAGE HYDRAULIC SYSTEM

Hydraulic Ram Output provides more force for reliable connection

■ ERGONOMIC DESIGN

With light weight and inline grip, easily work overhead and in tight spaces.

■ SERVICE INTERVAL: 30000 Cycles

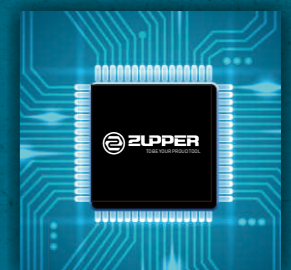

CIRCUIT BOARD DIAGNOSTICS
Alert you when the battery is low or the tool is too hot or cold

SMALLER, FASTER, LIGHTER
**COMPACT MEASURES
HUGE POWER**

PZ-1930

BATTERY POWERED PRESS TOOL
precise pressing with lighter body

- 15-28mm(1/2"-1")Stainless Pipe
- 15-35mm(1/2"-1 1/2")Copper Pipe
- 16-32mm PEX & Multi-layer Pipe

The PZ-1930 is the newest addition to the mini press tool with in-line grip, it is efficient and reliable way to join copper, stainless steel and PEX&Multi-layer Pipe.



COPPER PIPE



MULTI-LAYER COMPOSITE PIPE



PEX PIPE



STAINLESS STEEL PIPE



SPECIFICATIONS

Capacity:	12-28mm(1/2"-1") Stainless steel pipe, 12-35mm(1/2"-1") Copper pipe, 12-32mm PEX&Multi-layer pipe	Battery:	18V Li-ion 2.5Ah
Output:	19KN	Battery Charger:	AC 100-240V
Stroke:	30mm	Charging Time:	Approx. 50mins
Oil capacity:	Approx. 60ml	Service Interval:	Service Interval: 30000cycles
Crimping Cycle Time:	2-4S	Weight:	Approx.2.0kgs (tool with battery) Approx. 3.5kgs(tool with battery and jaw)
Crimping Cycles/charge:	180cycles (DN 20 Stainless Steel)	Tool Size:	Tool Size: 363×120×75mm

MODEL NO.	DESCRIPTION	Weight (KGS)	Standard Pack
PZ-1930	PZ-1930 Battery Press Tool Kit without jaws	6.10	1pc
ACCESSORIES	18V, 2.5 Ah Li-Ion Batteries	0.35	2pcs
	Charger	0.70	1pc
	Plastic case	2.90	1pc
	Sealing ring of cylinder:		1set
	Sealing ring of safety valve:		1set

Advantage of Zupper press jaw

Connecting Plate

- Precision stamping
- Security design

Serial NO.

- Tracking numbers easier to do after-sales service



Precision Forged Jaws

- Made by multi-axis CNC machine
- High strength, sturdy and durable

Special heat treatment process

- Inspection control program to ensure long span life

ZUPPER TOOL have a wealth of design and practical experience, can provide customers with differentiated solutions according to customer needs, and to offer customers with pipe press technical support.

Suitable press tool

- Compact series press jaws, suit for output 19KN press tool:
PZ-1930, BZ-1930, EZ-1930 and so on
- Standard series press jaws, suit for output 32KN press tool:
PZ-1550, CZ-1550, EB-1550, ED-1550, BZ-1550, HH-1550, HZ-1550, FHT-1550 and so on
- Thicken series press jaws, suit for output 50KN press tool:
ED-5050, HH-5050 and so on



Compact series press jaws

Standard series press jaws

Thicken series press jaws



Universal Jaw with interchangeable dies fit for PEX pipe
Economic design for any need

Adaptor /Press Rings for 42-54mm

Interchangeable dies

- 1) One universal jaw with different types of dies, with a high cost performance
- 2) Quick change mounting for replace the dies easily

NOTE:The economic design only for PEX or PAP pipe, not for stainless pipe and copper pipes.

Standard Series Press Jaws & Press Rings

DESCRIPTION	JAW SIZE	Weight (KGS)	
PEX & MULTI-LAYER PIPE	TH16	2.05	
	TH20	2.00	
	TH25	-	
	TH26	2.05	
	TH32	2.10	
	TH40	-	

DESCRIPTION	JAW SIZE	Weight (KGS)	
PEX & MULTI-LAYER PIPE	U16	1.95	
	U20	2.05	
	U25	2.00	
	U32	2.15	
	U40	2.20	
	U50	-	
	U63	2.47	

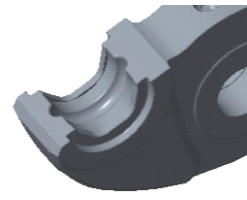
DESCRIPTION	JAW SIZE	Weight (KGS)	
FOR STAINLESS STEEL PIPE	SV13	2.01	
	SV20	2.07	
	SV25	2.03	
	SV30	-	

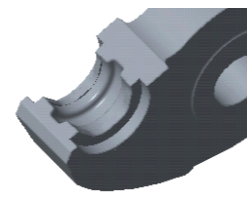
DESCRIPTION	JAW SIZE	Weight (KGS)	
FOR COPPER PIPE	VAU15	2.00	
	VAU20	2.06	
	VAU25	2.04	
	VAU32	2.09	
	VAU40	1.48	
	VAU50	1.75	

Special jaws can be made according to your requirements.

Standard Series Press Jaws

DESCRIPTION	JAW SIZE	Weight (KGS)	
FOR COPPER PIPE	VUS1/2"	2.00	
	VUS3/4"	2.10	
	VUS1"	2.05	
	VUS1-1/4"	2.08	
	VUS1-1/2"	4.30	
	VUS2"	4.18	

DESCRIPTION	JAW SIZE	Weight (KGS)	
FOR STAINLESS STEEL /COPPER PIPE	M12	2.00	
	M15	2.00	
	M18	1.95	
	M22	2.00	
	M28	2.00	
	M35	2.05	
	M42	1.35	
	M54	1.60	

DESCRIPTION	JAW SIZE	Weight (KGS)	
FOR STAINLESS STEEL /COPPER PIPE	V12	2.02	
	V15	1.95	
	V18	2.10	
	V22	2.05	
	V28	2.00	
	V35	2.05	
	V42	1.40	
	V54	1.63	

Special jaws can be made according to your requirements.

Compact Series Press Jaws

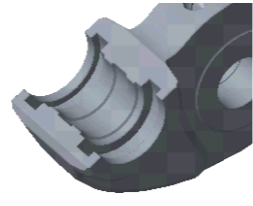
DESCRIPTION	JAW SIZE	Weight (KGS)	
PEX& MULTI-LAYER PIPE	TH16	1.27	
	TH20	1.33	
	TH25	1.41	
	TH26	1.35	
	TH32	1.40	

DESCRIPTION	JAW SIZE	Weight (KGS)	
PEX& MULTI-LAYER PIPE	U16	1.20	
	U20	1.29	
	U25	1.30	
	U32	1.50	

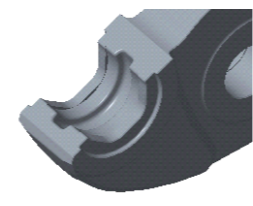
DESCRIPTION	JAW SIZE	Weight (KGS)	
FOR STAINLESS STEEL /COPPER PIPE	M12	1.23	
	M15	1.30	
	M18	1.29	
	M22	1.37	
	M28	1.39	

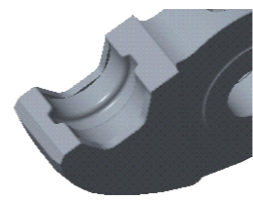
DESCRIPTION	JAW SIZE	Weight (KGS)	
FOR STAINLESS STEEL /COPPER PIPE	V12	1.23	
	V15	1.23	
	V18	1.29	
	V22	1.38	
	V28	1.47	

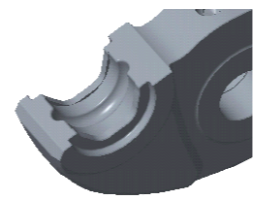
DESCRIPTION	JAW SIZE	Weight (KGS)	
FOR STAINLESS STEEL PIPE	SV13	1.23	
	SV20	1.27	
	SV25	1.34	
	SV30	-	

Compact Series Press Jaws

DESCRIPTION	JAW SIZE	Weight (KGS)	
FOR COPPER PIPE	VAU15	1.23	
	VAU20	1.28	
	VAU25	1.35	
	VAU32	1.49	

DESCRIPTION	JAW SIZE	Weight (KGS)	
FOR COPPER PIPE	VUS1/2"	1.23	
	VUS3/4"	1.26	
	VUS1"	1.48	

Special jaws can be made according to your requirements.

Special jaws can be made according to your requirements.